



INSTALLATION GUIDE

BioEntry W2

English

Version 1.00

Contents

Safety Instructions	3
Introduction	5
Components	5
Name and function of each part.....	6
Cables and connectors.....	7
How to enroll a fingerprint	8
Selecting a finger for fingerprint input.....	8
Fingerprint enroll method	8
Installation	9
Fixing the bracket and the product.....	9
Power supply connection.....	10
Network connection.....	10
TCP/IP	10
TTL input connection	11
Relay connection.....	12
Fail Safe Lock.....	12
Fail Secure Lock.....	12
Automatic door connection	13
Connecting as a standalone.....	14
Connecting to Secure I/O 2	15
Wiegand connection	16
Resetting Network Settings.....	16
Product specifications.....	17
Dimensions.....	18
FCC Compliance Information	19
Appendix	20
Escape clause.....	20
Copyright notice.....	20

Safety Instructions

Observe the following instructions to use the product safely and prevent any risk of injury or property damage.

Warning

Noncompliance of instructions could lead to serious injury or death.

Installation

Do not install the product in a place with direct sunlight, moisture, dust, or soot.

- A fire or electric shock may occur.

Do not install the product in a place with heat from an electric heater.

- A fire or electric shock may occur due to overheating.

Install the product in a dry place.

- Otherwise, a product damage or electric shock may occur due to moisture.

Install the product in a place with no electromagnetic interference.

- Otherwise, a product damage or electric shock may occur.

The user should not install or repair the product independently.

- A fire, electric shock, or personal injury may occur.
- If the product has been damaged due to independent installation or repair of the product by the user, free A/S service will not be provided.

Operation

Do not allow liquids such as water, beverages, or chemicals get into the product.

- A fire, electric shock, or product damage may occur.

Caution

Noncompliance of instructions could lead to minor injury or product damage.

Installation

Do not install the power supply cable in a place where people pass by.

- Product damage or physical injury may occur.

Do not install the product near a highly magnetic object such as a magnet, TV, (especially CRT) monitor, or speaker.

- A product failure may occur.

If installing the product outside where the product is completely exposed, it is recommended to install the product together with the enclosure.

Use a separate power supply for Secure I/O 2, electric lock and BioEntry W2 respectively.

- If connecting and using the power supply to these devices together, the devices may malfunction.

When installing a number of devices, allow a space between the devices for installation.

- Otherwise, one device may affect the RF performance of other devices, resulting in malfunction.

Operation

Do not drop the product or apply an impact to the product.

- A product failure may occur.

Be careful not to contaminate or damage the fingerprint contact unit with a dirty hand or foreign substances.

- Deterioration in fingerprint authentication performance and a product failure may occur.

When cleaning the product, wipe the product with a soft and dry cloth and no water, benzene or alcohol.

- Otherwise, a product failure may occur.

RTC battery

Replacing the battery with an incorrect type of battery may cause explosion.

Discard the battery according to the appropriate regional or international waste regulations.

Introduction

Components

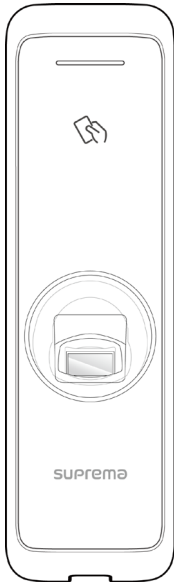

BioEntry W2

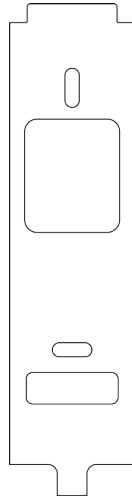

Bracket

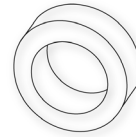
Ferrite core
(1 EA)PVC anchor
(2 EA)

Heat shrink tubes

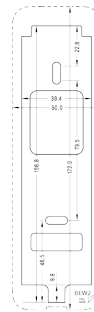
Fixing screw
(2 EA)120 Ω resistor
(1 EA)Diode
(1 EA)

Drilling template

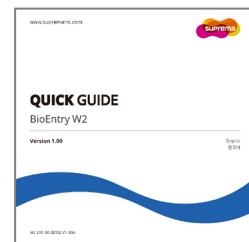

Quick guide

Note

Components may vary according to the installation environment.

Name and function of each part

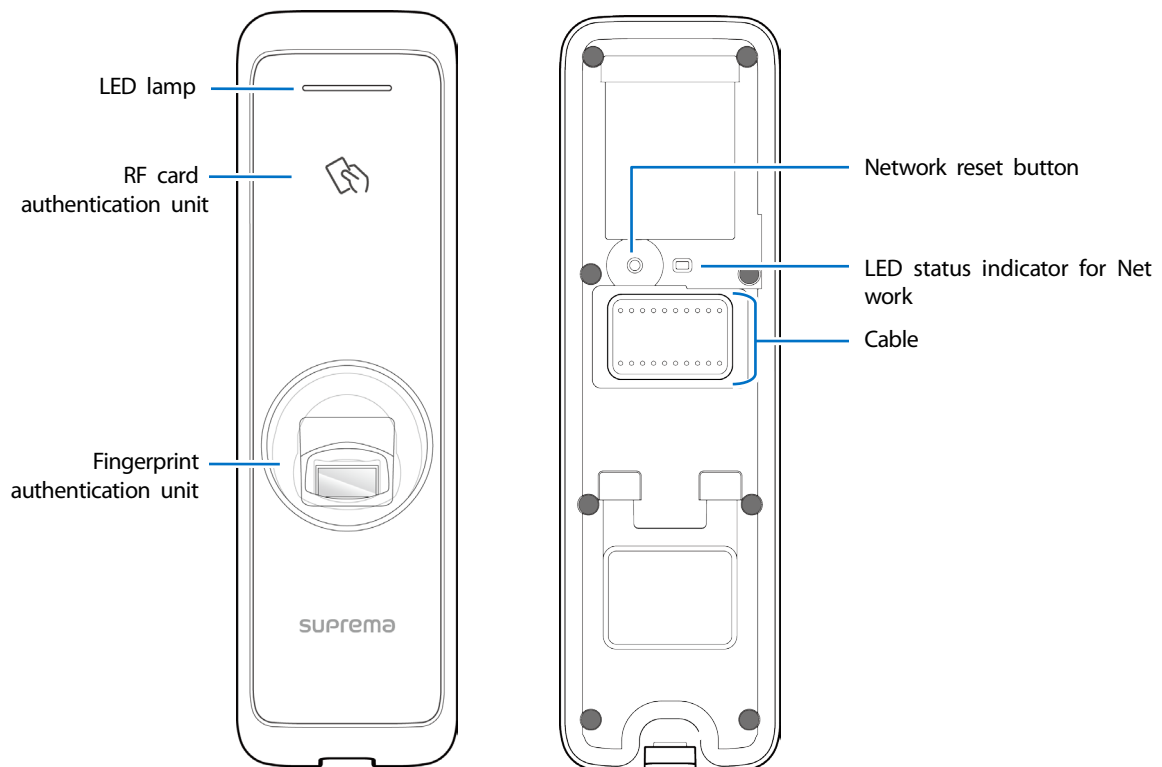

Name	Feature
LED lamp	Indicates the operational status of the product with the color of the LED lamp.
RF card authentication unit	Reads RF cards for entering and exiting.
Fingerprint authentication unit	Reads fingerprints placed on it for entering and exiting.
Cable	<ul style="list-style-type: none"> • TTL input cable • Wiegand input or output cable • Power cable • RS485 cable • Ethernet connector • Relay output cable
LED lamp for Network	Shows the status of the network connection.
Network reset button	Resets the network configuration. For details, refer to the Resetting Network Setting .

Cables and connectors

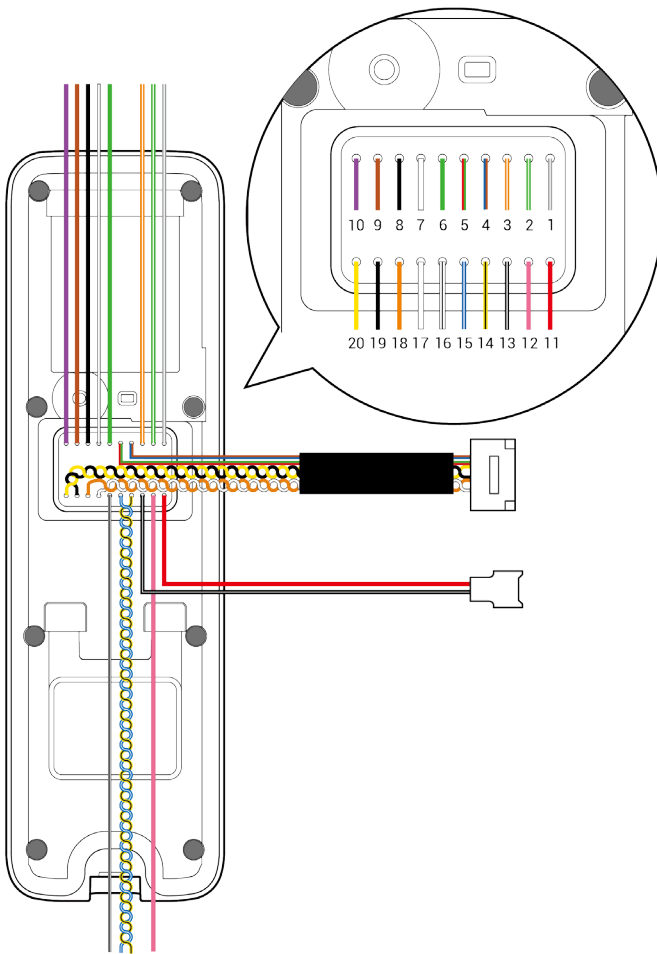

Pin	Name	Color
1	RLY NO	Gray (White stripe)
2	RLY COM	Green (White stripe)
3	RLY NC	Orange (White stripe)
4	VB2	Blue
		Brown
5	VB1	Red
		Green
6	WG D0	Green
7	WG D1	White
8	WG GND	Black
9	TTL IN 1	Brown
10	TTL IN 0	Purple
11	PWR +VDC	Red
12	Not Connected	Pink
13	PWR GND	Black (White stripe)
14	485 TRXN	Yellow (Black stripe)
15	485 TRXP	Blue (White stripe)
16	485 GND	White (Black stripe)
17	ENET TXP	White
18	ENET TXN	Orange
19	ENET RXP	Black
20	ENET RXN	Yellow

How to enroll a fingerprint

In order to improve the fingerprint authentication rate, register the fingerprint correctly. BioEntry W2 can recognize a fingerprint even if the angle and position of a user's fingerprint input change. If you register the fingerprint with attention to the following matters, the authentication rate can be improved.

Selecting a finger for fingerprint input

- In preparation for the case that the fingerprint of a specific finger cannot be used, for example if the user is lifting a load with one hand or a finger gets hurt, up to 10 fingerprints for each user can be registered.
- In the case of a user whose fingerprint cannot be recognized well, the authentication rate can be improved by enrolling the same finger twice repeatedly.
- If a finger has a cut or the fingerprint is blurry, select another finger for the fingerprint.
- It is recommended to use the index finger or the middle finger when scanning the fingerprint. The authentication rate can be reduced if it is difficult to place another finger at the center of fingerprint sensor accurately.

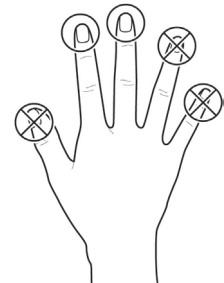

Fingerprint enroll method

- 1 Place the finger with the fingerprint to be registered on the fingerprint authentication unit and press the finger gently for better authentication.

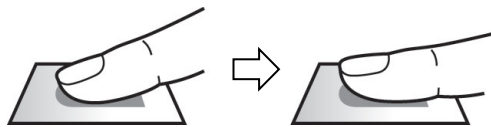

- 2 After a beep sounds, scan the fingerprint of the registered finger again (scan the fingerprint of a finger to be registered twice).

Note

Cautions for enrolling a fingerprint

When a fingerprint is recognized, it is compared with the initially registered fingerprint, so the initial fingerprint enroll is the most important. Pay attention to the following matters when enrolling the fingerprint.

- Place the finger deep enough to contact with the sensor completely.
- Place the center of the fingerprint in the center of the sensor.
- If a finger has a cut or the fingerprint is blurry, select another finger for the fingerprint.
- Scan the fingerprint correctly without moving according to the instruction on the screen.
- If you make the finger upright so that the contact area with the sensor has decreased or the angle of finger has warped, fingerprint authentication may not be performed.



When the fingerprint recognition fails

BioEntry W2 can recognize a fingerprint regardless of a change of season or finger condition. However, the authentication rate may vary according to the external environment or fingerprint input method.

If the fingerprint authentication cannot be done smoothly, it is recommended to take the following measures.

- If the finger is smeared with water or sweat, dry off the finger and then scan the finger.
- If the finger is too dry, blow your breath on the fingertips and then scan the finger.
- If the finger has a cut, register the fingerprint of another finger.
- The initially registered fingerprint often may have not been scanned correctly, so register the fingerprint again according to 'Cautions for enrolling a fingerprint'.

Installation

Fixing the bracket and the product

- 1 Determine the correct position to install the bracket using the provided drilling template. Fix the bracket firmly using fixing screws through the bracket to the position where BioEntry W2 will be installed.

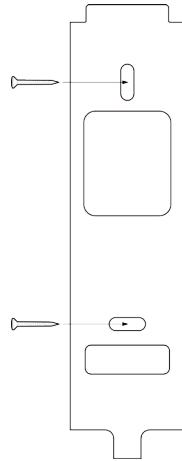

Note

- If installing BioEntry W2 on a concrete wall, drill holes, insert PVC anchors, and fix them with fixing screws.
- To avoid RF interference, a minimum separation distance must be maintained.

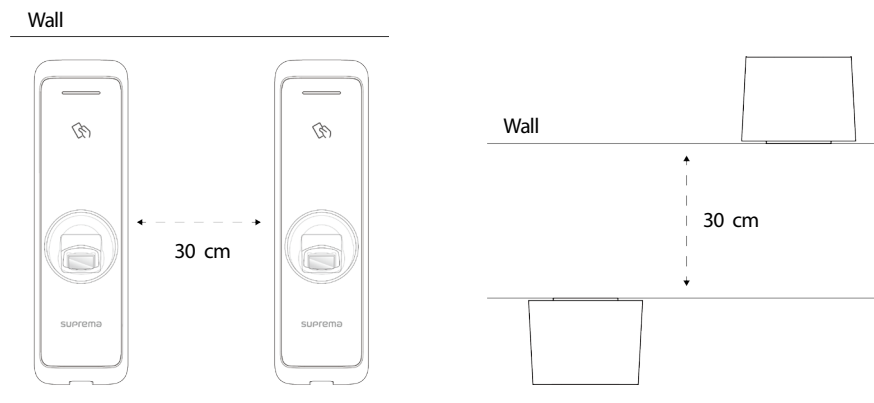

- 2 Install BioEntry W2 onto the fixed bracket.

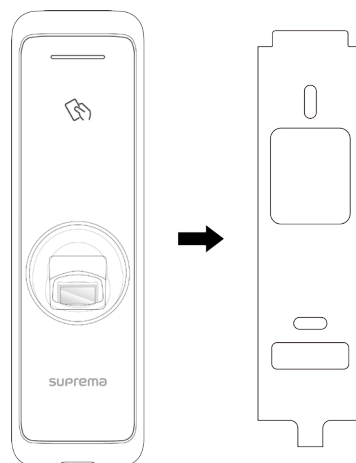

- 3** Connect BioEntry W2 to the bracket by rotating the product fixing screw.

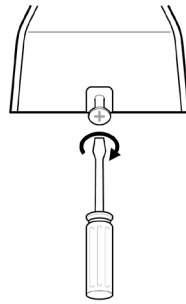

Power supply connection

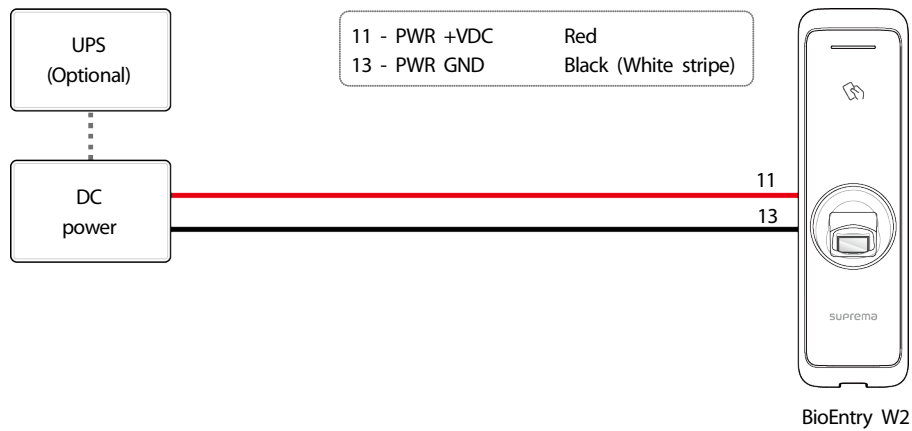

Note

- Use a power supply adaptor of DC 12 V (\pm 10%) with a minimum of 1,500 mA which has obtained the approval of IEC/EN 60950-1. If you wish to connect and use another device to the power supply adaptor, you should use an adaptor with a current capacity which is the same or larger than the total power consumption required for the terminal and another device.
- Use a separate power supply for Secure I/O 2, the electric lock, and the BioEntry W2 respectively. If connecting and using the power supply to these devices together, the devices may malfunction.

Network connection

TCP/IP

LAN connection (connecting to a hub)

You can connect the product to a hub using a general type CAT-5 cable.

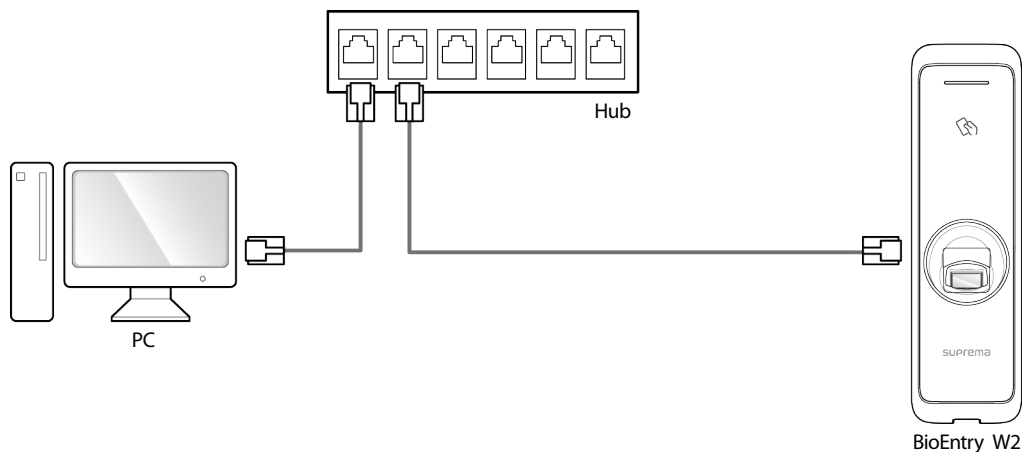

LAN connection (connecting to a PC directly)

BioEntry W2 has an automatic MDI/MDIX function so that it can be connected to a PC directly using a normal straight type CAT-5 cable, not a cross cable.



TTL input connection

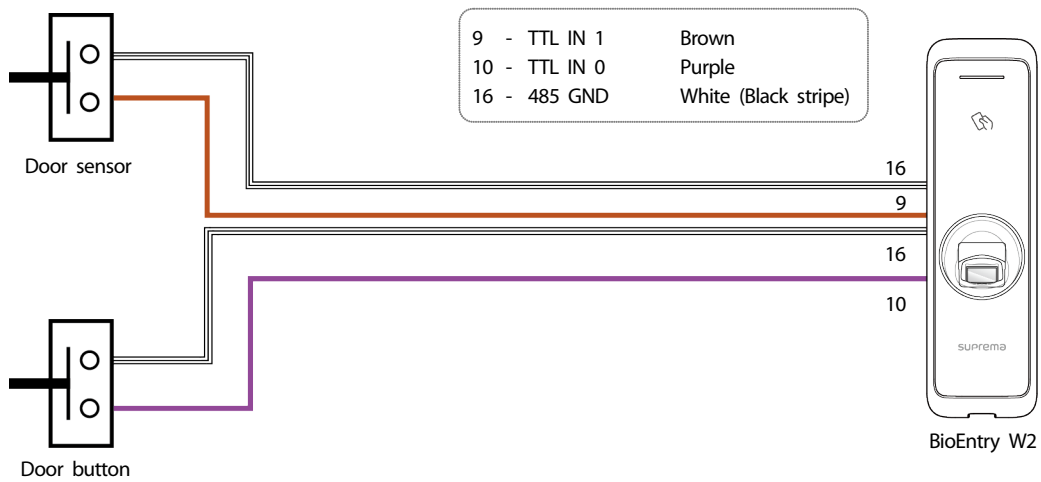

Relay connection

Fail Safe Lock

In order to use the Fail Safe Lock, connect N/C relay as shown in the figure below. There is normally a current flowing through the relay for the Fail Safe Lock. When the relay is activated, blocking the current flow, the door will open. If the power supply to the product is cut off due to a power failure or an external factor, the door will open.

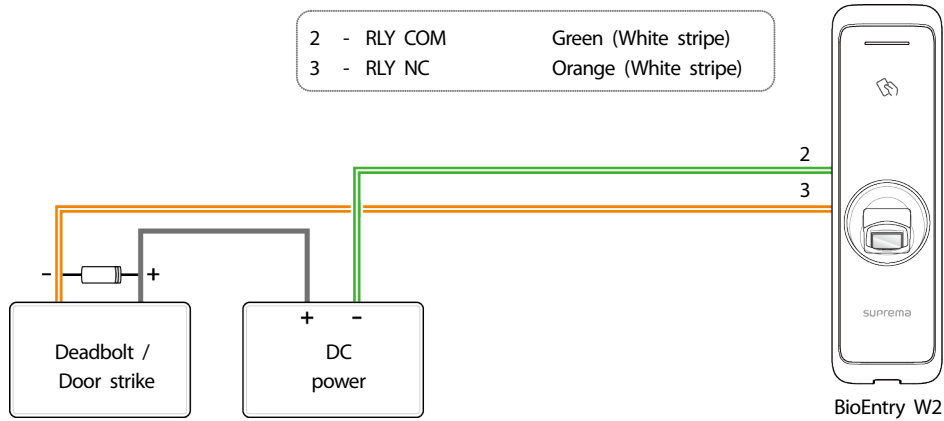

Note

- Install a diode at both sides of the door lock wire as shown in the figure to protect the relay from the reverse current, which occurs when the door lock operates.
- Take caution of the installation direction of the diode. Install the diode close to the door lock.
- Use a separate power supply for BioEntry W2 and the door lock.

Fail Secure Lock

In order to use the Fail Secure Lock, connect N/O relay as shown in the figure below. There is normally no current flowing through the relay for the Fail Secure Lock. When the current flow is activated by the relay, the door will open. If the power supply to the product is cut off due to a power failure or an external factor, the door will lock.

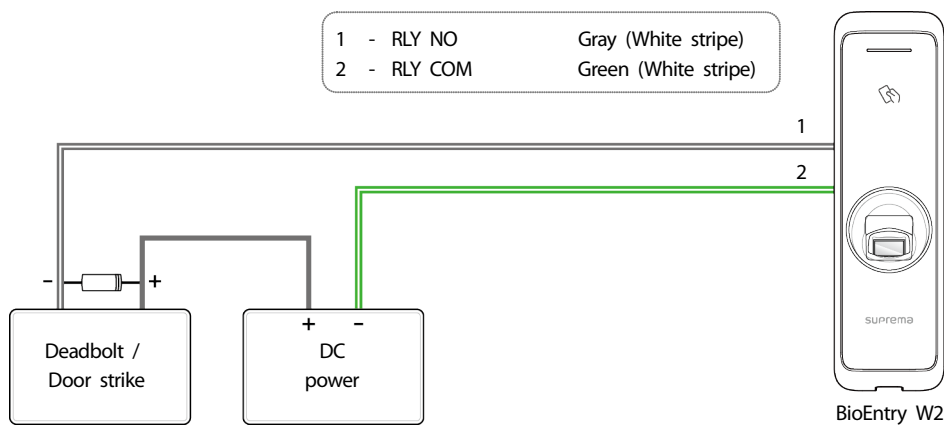

Note

- Install a diode at both sides of the door lock wire as shown in the figure to protect the relay from the reverse current, which occurs when the door lock operates.
- Take caution of the installation direction of the diode. Install the diode close to the door lock.
- Use a separate power supply for BioEntry W2 and the door lock.

Automatic door connection

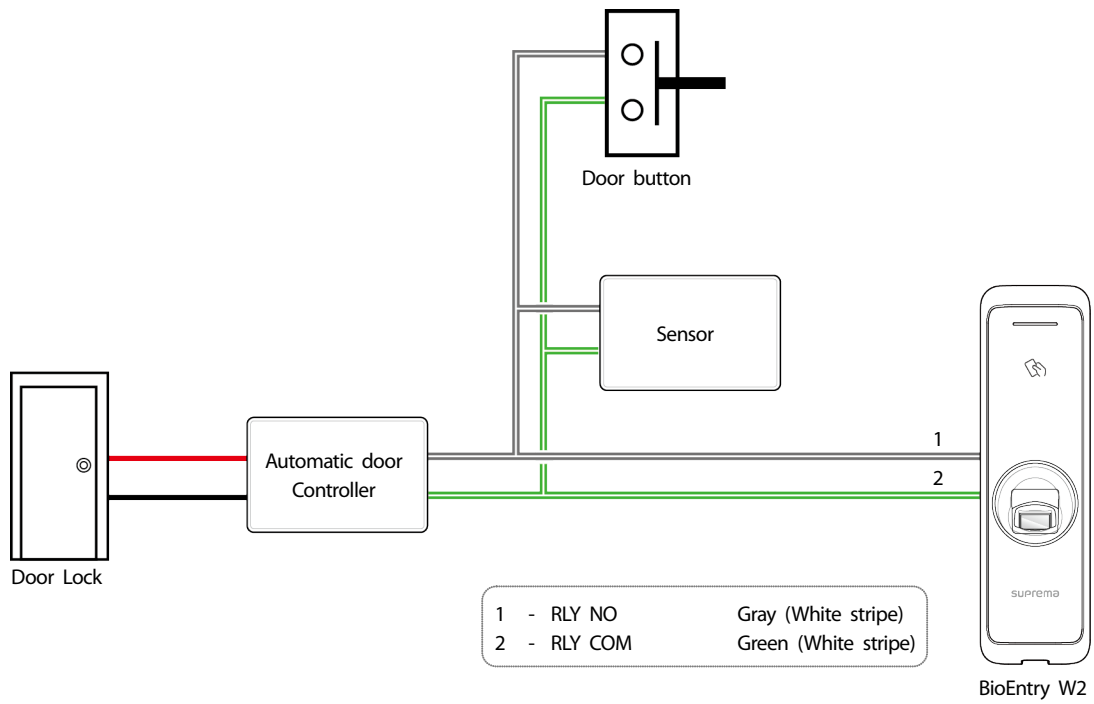

Connecting as a standalone

BioEntry W2 can be connected to the door lock, door button, and door sensor directly without connecting a separate I/O device.

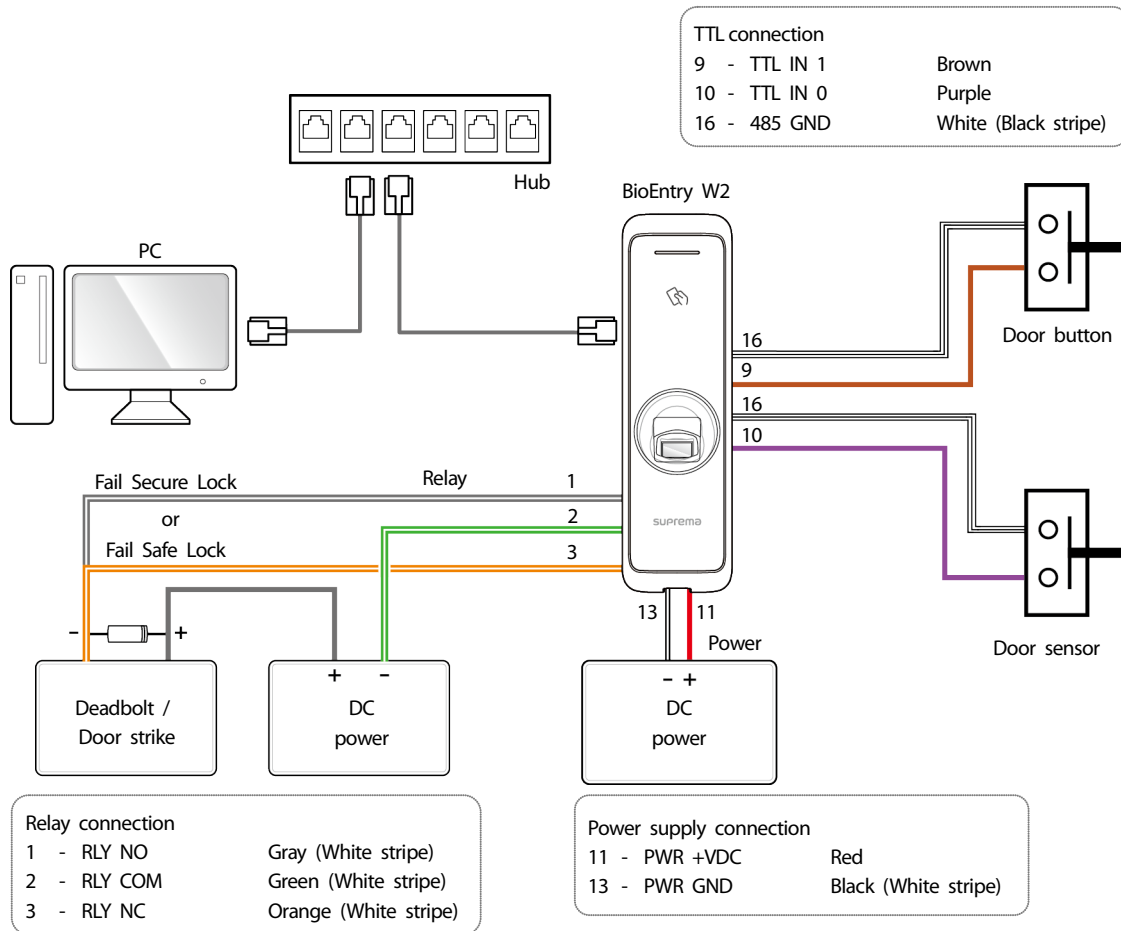

Note

- BioEntry W2 can be used as a multi-door controller with the slave devices with the RS485 cable. The slave devices are used as dummy readers and authentication is performed in the master device.
- If Xpass is connected to the master device, only card authentication can be used.
- The maximum number of slave devices available to connect varies according to the authentication method, number of users, and number of devices. Also note that the number of slave devices affects the fingerprint authentication speed.
- A master device can control 31 slave devices. The bandwidth of RS485 allows for up to 7 fingerprint authentication devices to be connected.
- For more information, contact the Suprema technical support team (support@suprema.co.kr).

Wiegand connection

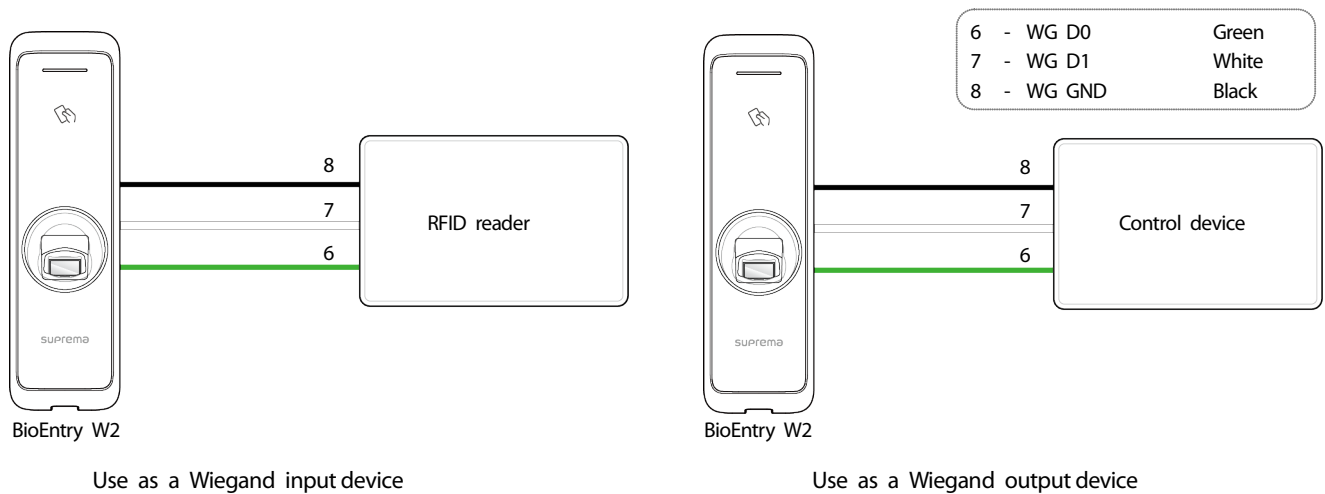

Resetting Network Settings

- 1** Turn the power on.
- 2** Press the network reset button on the rear of device until the device restart automatically.
- 3** Connect the device with default values.
 - TCP/IP address: DHCP address assignment (If DHCP address assignment is failed, 169.254.x.x will be set.)
 - Server mode: Disabled
 - RS-485: PC connection, 115200 bps
- 4** Change the TCP/IP address or RS-485 information.
- 5** Turn the power off later on and then check the network setting is properly.

Product specifications

Category	Feature	Specification
Credential	Biometric	Fingerprint
	RF Option	125 KHz EM/HID Proxy, 13.56 MHz MIFARE/DESFire/DESFire EV1/Felica/NFC/iClass
	RF read range *	MIFARE/DESFire/EM/HID Proxy/iClass/ISO15693 : 50 mm, Felica: 30 mm
General	CPU	1.2 GHz Quad Core
	Memory	2GB Flash + 256 MB RAM
	LED	Multi-color
	Sound	Multi-tone Buzzer
	Operating temperature	-20°C - 50°C
	Storage temperature	-40°C - 70°C
	Operating humidity	0% - 80%, non-condensing
	Storage humidity	0% - 90%, non-condensing
	Dimension (W x H x D)	50 mm x 172 mm x 43.5 mm (Bottom) / 38.2 mm (Top)
	Weight	Device: 251g Bracket: 43g (Including washer and bolt)
	IP rating	IP67
	IK rating	IK08
	Certificates	CE, FCC, KC, RoHS, REACH, WEEE
Fingerprint	Image dimension	272 x 320 pixels
	Image bit depth	8bit, 256 grayscale
	Resolution	500 dpi
	Template	SUPREMA / ISO 19794-2 / ANSI 378
	Extractor / Matcher	MINEX certified and compliant
	LFD	Supported
Capacity	Max. User (1:1)	500,000
	Max. User (1:N)	100,000
	Max. Template (1:1)	1,000,000
	Max. Template (1:N)	200,000
	Max. Text Log	1,000,000
Interface	Ethernet	Supported (10/100 Mbps, auto MDI/MDI-X)
	RS-485	1ch Master / Slave (Selectable)
	Wiegand	1ch Input / Output (Selectable)
	TTL input	2ch Input
	Relay	1 Relay
	PoE	Supported
	Tamper	Supported
Electrical	Power	Voltage: DC 12 V Current: Max. 600 mA
	Switch input VIH	Min. 3 V Max. 5 V
	Switch input VIL	Max. 1 V
	Switch Pull-up resistance	4.7 k Ω (The input ports are pulled up with 4.7 k Ω .)
	Wiegand output VOH	More than 4.8 V
	Wiegand output VOL	Less than 0.2 V
	Wiegand output Pull-up resistance	Internally pulled up with 1 k Ω
	Relay	Voltage: Max. 30VDC Current: 1A

* RF read range will vary depending on the installation environment.

Dimensions

(Unit: mm)

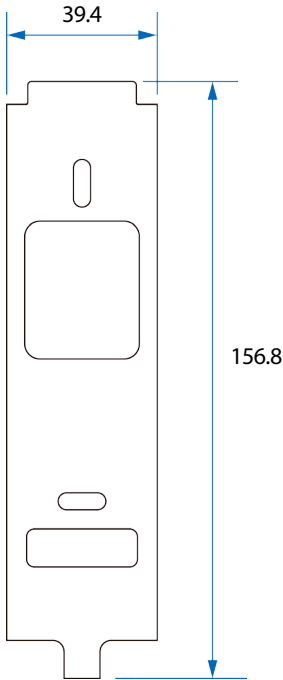
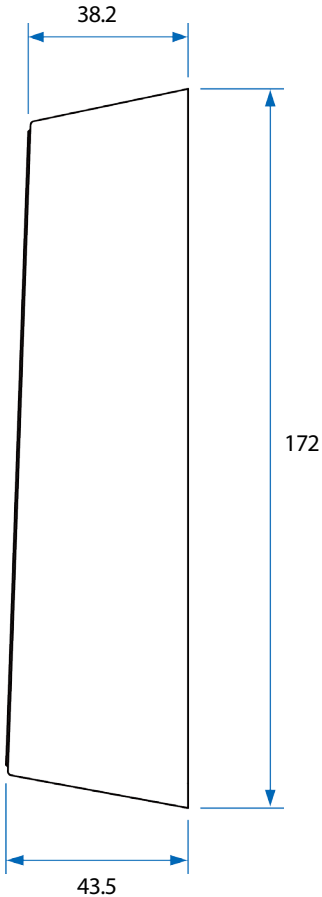
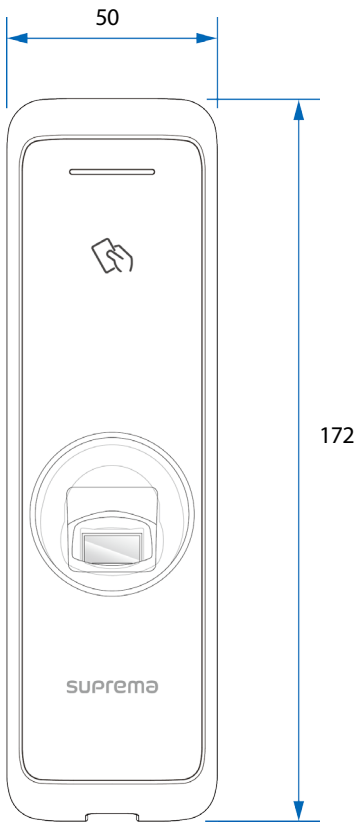

FCC Compliance Information

THIS DEVICE COMPLIES WITH PART 15 OF THE FCC RULES.

Operation is subject to the following two conditions:

- (1) This device may not cause harmful interference, and
- (2) This device must accept any interference received, including interference that may cause undesired operation.

Note: This equipment has been tested and found to comply with the limits for a Class B digital device, pursuant to part 15 of the FCC Rules. These limits are designed to provide reasonable protection against harmful interference in a residential installation. This equipment generates, uses, and can radiate radio frequency energy and, if not installed and used in accordance with the instructions, may cause harmful interference to radio communications. However, there is no guarantee that interference will not occur in a particular installation. If this equipment does cause harmful interference to radio or television reception, which can be determined by turning the equipment off and on, the user is encouraged to try to correct the interference by one or more of the following measures:

- Reorient or relocate the receiving antenna.
- Increase the separation between the equipment and receiver.
- Connect the equipment into an outlet on a circuit different from that to which the receiver is connected.
- Consult the dealer or an experienced radio/TV technician for help.

Modifications not expressly approved by the manufacturer could void the user's authority to operate the equipment under FCC rules.

This appliance and its antenna must not be co-located or operation in conjunction with any other antenna or transmitter. A minimum separation distance of 20 cm must be maintained between the antenna and the person for this appliance to satisfy the RF exposure requirements.

Appendix

Escape clause

- The information in this manual is provided with regard to the Suprema's products.
- The right to use is acknowledged only for products included in the terms and conditions of the sales agreement guaranteed by Suprema. The right of license to other intellectual property rights not discussed in this manual is not acknowledged.
- Suprema does not guarantee or hold responsibility for the suitability and commerciality of the product for a specific purpose, or the infringement of patent, copyright, or other intellectual property rights with regard to sales or usage of Suprema's products.
- Do not use the product of Suprema under the situations related to medical, rescue of human lives, or maintenance of life, as a person may get injured or lose his/her life due to product malfunction. If an accident occurs while a consumer is using the product under the situations described as examples above, employees, subsidiaries, branches, affiliated companies and distributors of Suprema do not accept responsibility nor will they reimburse for all related direct and indirect expenses or expenditure including attorney fees even if the consumer has discovered any shortcomings in the product design or manufacturing process and claims this as a significant fault.
- Suprema may modify the product size and specifications at any time without proper notice in order to improve the safety, function and design of the product. Designers must keep in mind that functions or descriptions indicated as "to be implemented" or "undefined" may change at any time. Suprema will implement or define such functions or descriptions in the near future and Suprema accepts no responsibility for compatibility issues and any other problems arising from such compatibility issues.
- If you wish to obtain the newest specifications before ordering the product, contact Suprema through a Sales Representative or local distributor of Suprema.

Copyright notice

The copyright of this document is vested in Suprema. The rights of other product names, trademarks and registered trademarks are vested in each individual or organization that owns such rights.



www.supremainc.com

Suprema Inc. 16F Parkview Office Tower, Jeongja-dong, Bundang-gu Seongnam, Gyeonggi, 463-863 Korea
Tel) +82-31-783-4502 Fax) +82-31-783-4503

Sales information sales@supremainc.com **Technical support** support@supremainc.com